

*undeformed*

*tail*

*tip*

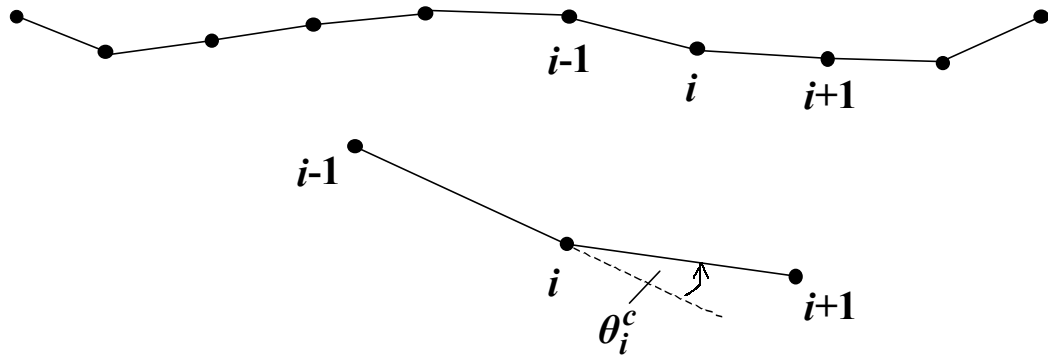

*deformed*

*tail*

*tip*

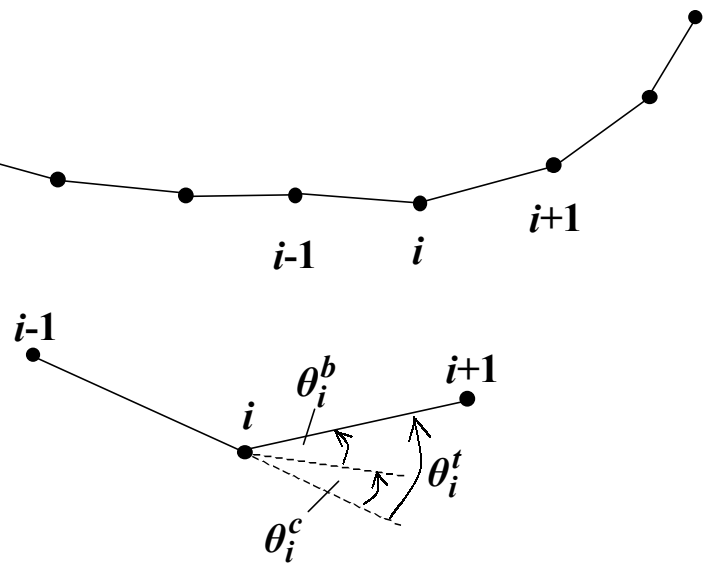
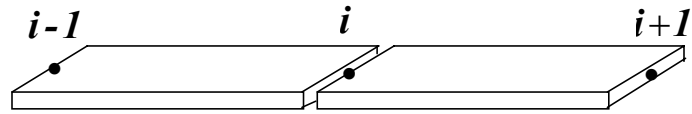

Figure F.10: The total bending angle  $\theta_i^t$  consisting of the camber angle  $\theta_i^c$  and the bending angle  $\theta_i^b$ .

*undeformed*



*deformed*

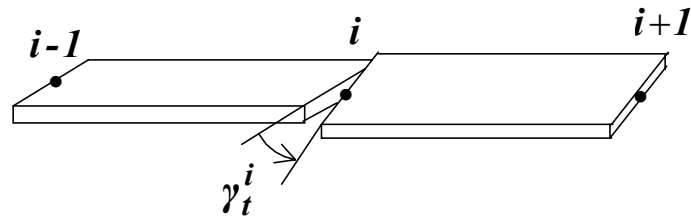

Figure F.11: The twist angle used to calculate snowboard shape.

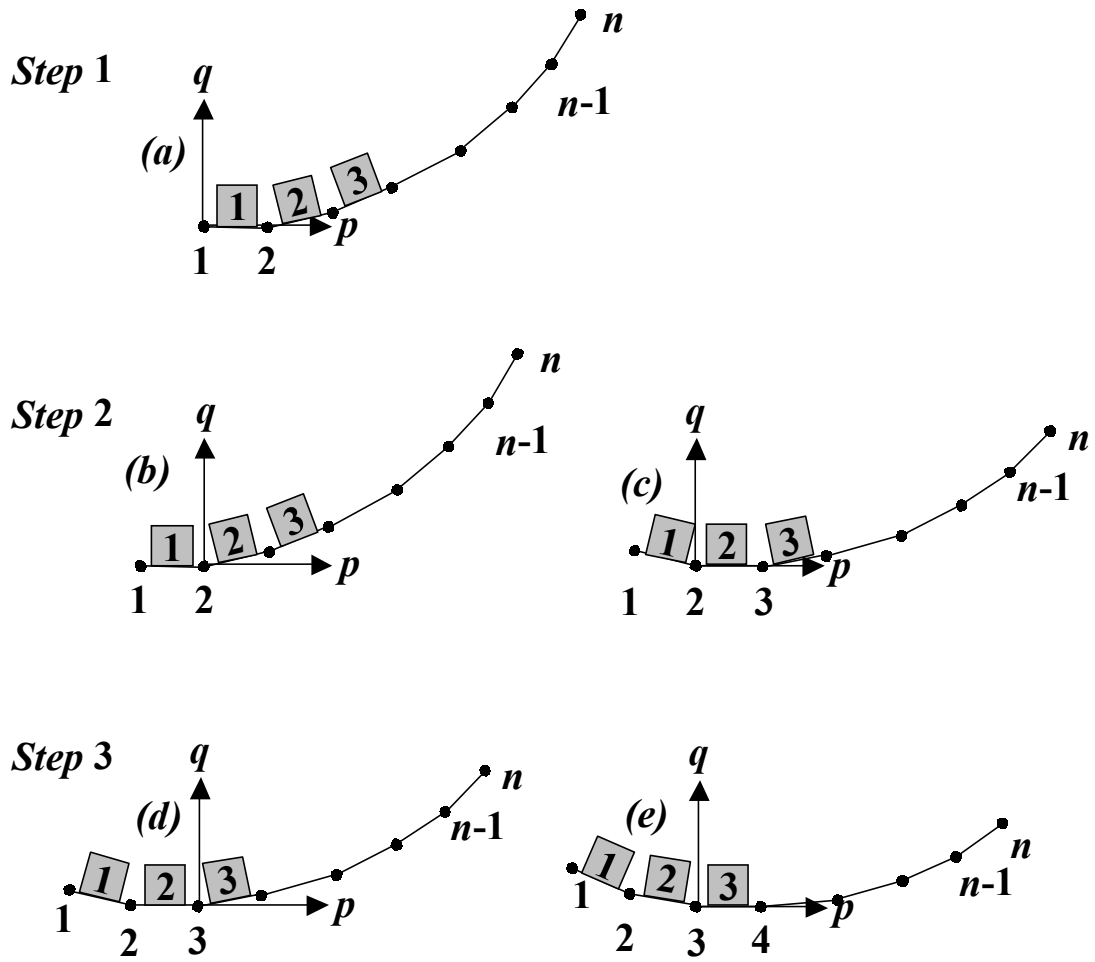

Figure F.12: Stage 1 in the determination of the snowboard position.

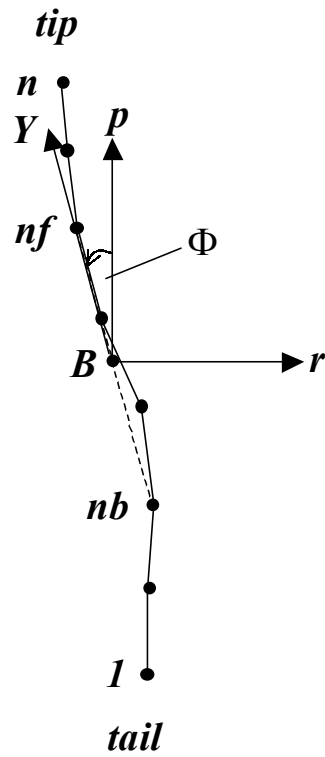
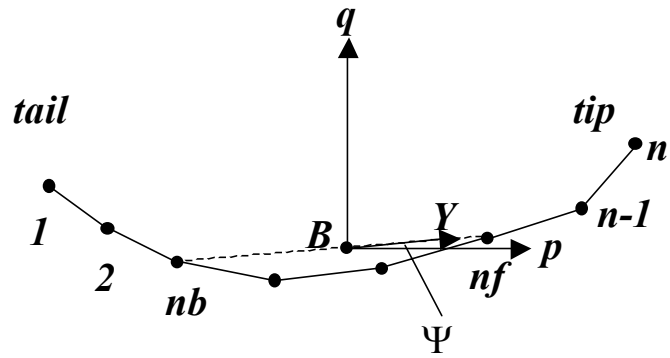

Figure F.13: The orientation of the  $Y$  axis with respect to the  $p$ - $q$ - $r$  coordinate system.

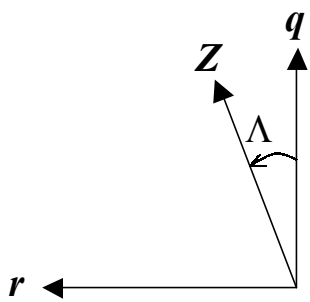

Figure F.14: The angle  $\Lambda$  between the  $Z$  axis and the  $q$  axis in the  $q-r$  plane.

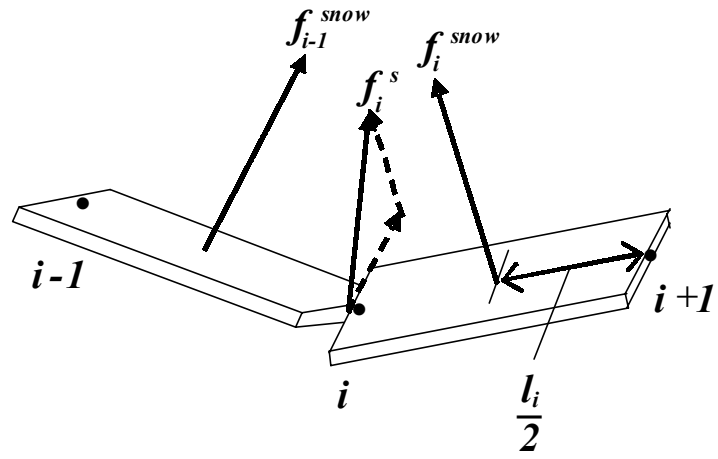

Figure F.15: The snow force applied at the  $i$ th node.

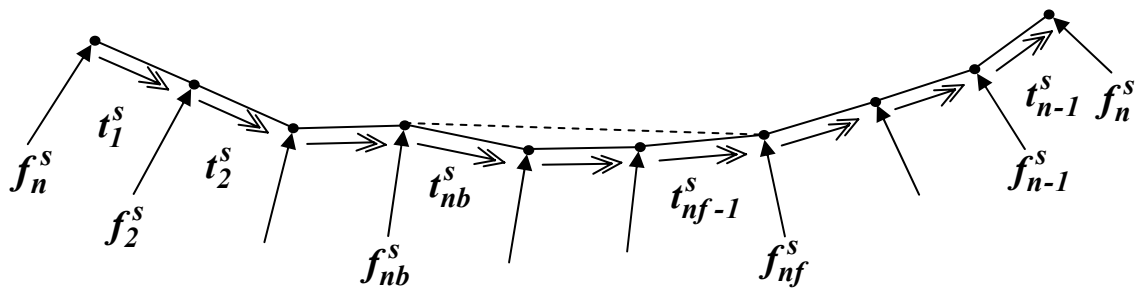

Figure F.16: The snow forces acting at in the local  $z$  direction and the nodes and the snow torques acting in the local  $y$  direction at the mid-segment.

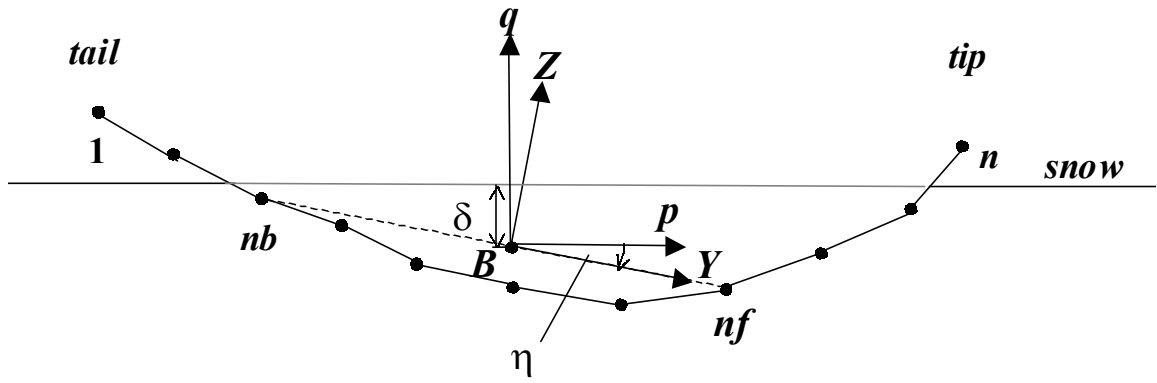

Figure F.17: The position of the snowboard in the snow.

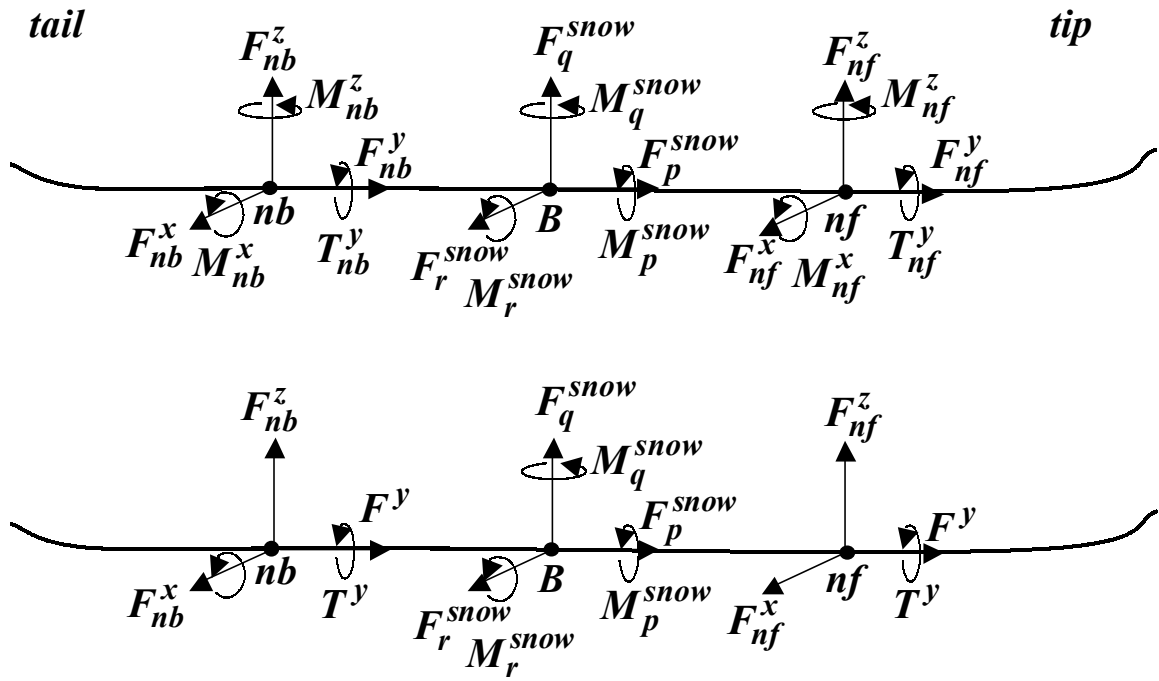

Figure F.18: The boot forces applied to the snowboard at the two boots and the equivalent snow forces at point B.

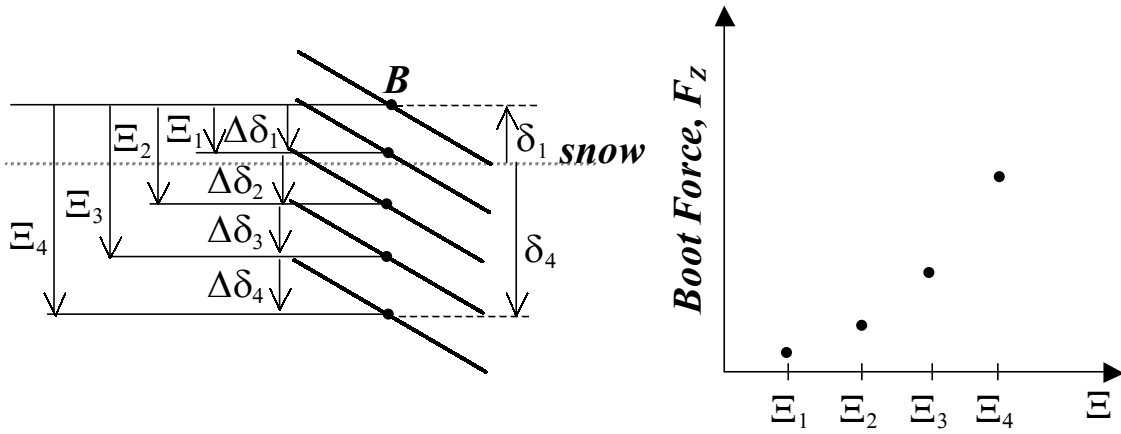

Figure F.19: The relationship between boot force  $F_Z = \left(F_{nb}^z\right)_Z + \left(F_{nf}^z\right)_Z$  (snowboard-fixed Z direction) and the depth of point  $B$  relative to the snow surface ( $q$  direction),

$$\text{where } \left(F_{nb}^z\right)_Z = \begin{Bmatrix} 0 & 0 & 1 \end{Bmatrix} [T_{SG}]^{-1} [T_{LG}]_{nb}^{node} \begin{Bmatrix} 0 \\ 0 \\ F_{nb}^z \end{Bmatrix}.$$

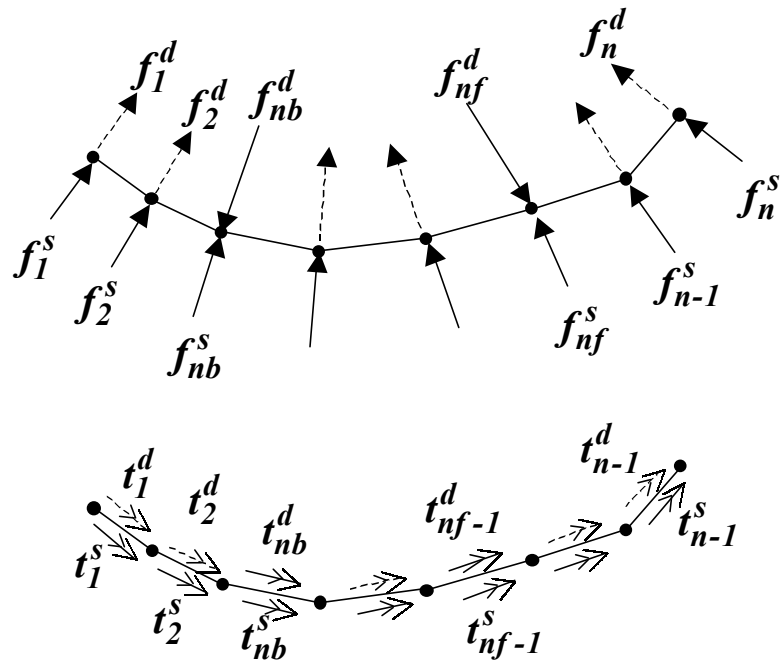

Figure F.20: The snow forces  $f^s$  and torques  $t^s$  and the equilibrating forces  $f^d$  and torques  $t^d$  acting on the snowboard. At the boot nodes  $f_{nb}^d = F_{nb}^z, f_{nf}^d = F_{nf}^z$ , while at the boot elements  $t_{nb}^d = t_{nf-1}^d = T^y$ .

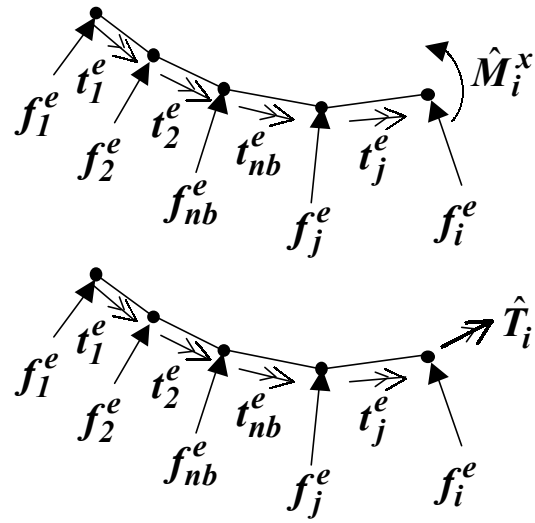

Figure F.21: The internal moment  $\hat{M}_i^x$  and torque  $\hat{T}_i$  at node  $i$  and the associated equilibrium forces  $f^e$  and torques  $t^e$ .

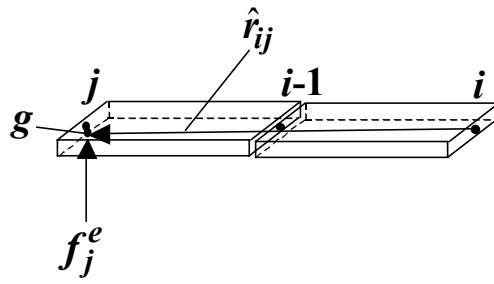

Figure F.22: The position vector  $\hat{r}_{ij}$  between node  $i$  and the base of the snowboard at node  $j$ .

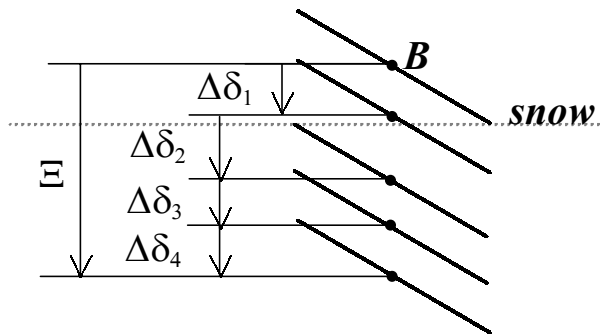

Figure F.23: The incremental displacement of the snowboard into the snow. The pitch  $\eta$ , roll  $\beta$ , and yaw  $\alpha$  are prescribed while the depth of point  $B$  is changed.

# Bibliography

- [1] Sutton, E.B. (2000) Better Snowboards by Design. *Proceedings of IMECE: International Mechanical Engineering Congress & Exposition*, November 5-10, 2000 Orlando, FL, USA.
  
- [2] Nordt, A.A., Springer, G.S. & Kollar, L.P. (1999) Computing the mechanical properties of alpine skis. *Sports Engineering*, **2**, 65-84.
  
- [3] Nordt, A.A., Springer, G.S. & Kollar, L.P. (1999) Simulation of a turn on alpine skis. *Sports Engineering*, **2**, 181-199.
  
- [4] Kollar, L.P. & Springer, G.S. (2003) *Mechanics of Composite Structures*. Cambridge University Press, New York, NY, USA.
  
- [5] Cook, R.D. (1989) *Concepts and Applications of Finite Element Analysis*. 3<sup>rd</sup> ed. John Wiley and Sons, Inc., New York, NY, USA.
  
- [6] Roark, R.J. (1989) *Roark's Formulas for Stress and Strain*. 6<sup>th</sup> ed. McGraw-Hill, Inc, New York, NY, USA.
  
- [7] Brown, C.A. & Outwater, J.O. (1989) On the skiability of snow. *Skiing Trauma and Safety: Seventh International Symposium*, ASTM STP 1022, 329-336.
  
- [8] MathWorks, Inc. (2002) *MATLAB Version 6.5.0* [Computer Program]. Natick, MA, USA.

- [9] Chapra, S.C. & Canale, R.P. (1998) *Numerical Methods for Engineers: with Programming and Software Applications*. 3<sup>rd</sup> ed. WCB/McGraw-Hill, New York, New York, USA.
- [10] Lind, D. & Sanders, S.P. (1997) *The Physics of Skiing: Skiing at the triple point*. American Institute of Physics, Woodbury, NY, USA.
- [11] Spong, M. W. (1989) *Robot Dynamics and Control*. John Wiley and Sons, Inc., New York, NY, USA.
- [12] Birkoff, G. & Rota, G. (1962) *Ordinary Differential Equations*. Ginn and Co. New York, New York, USA.
- [13] Beer, F.P. & Johnston, E.R. (1992) *Mechanics of Materials*. 2<sup>nd</sup> ed. McGraw-Hill, Inc, New York, NY, USA.
- [14] Greenwood, D.T. (1988) *Principles of Dynamics*. 2<sup>nd</sup> ed. Prentice Hall, Inc, Englewood Cliffs, New Jersey, USA.